

Basic Electrical Wiring Information and Diagrams for Models 5100, 8000, 9600 and 9300 Series

Hard wiring (HW)

All motors come with a 4 wire 18 gauge grounded pigtail. This consists of a neutral, two directional wires, and a ground. This type of wiring is used when the motor is to be controlled by a recessed wall switch. The pigtail is connected by either hard wiring or a plug/receptacle. A single motor is controlled by an SPDT (single pole, double throw) switch. Two motors can be controlled together by a DPDT (double pole, double throw) switch. When more than two motors are to be controlled by a single switch, isolation (parallel) relays are required for each motor.

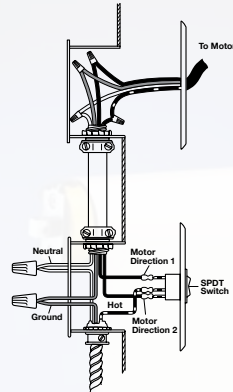

Standard Hard wiring

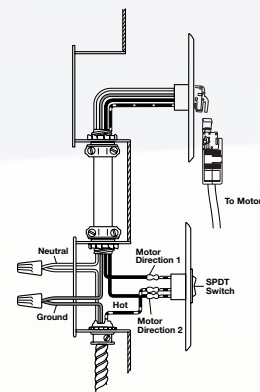

Hard wiring with optional plug/receptacle

Hard wiring with Isolation (Parallel) Relays (HW/ISO)

This variation of hard wiring is used when controlling two or more motors simultaneously from a single SPDT switch. Each motor's pigtail (with relay incorporated) is connected either by hard wiring or by plug/receptacle to an individual junction box. The wiring from each junction box is connected from one to the next; with the wiring from the terminal junction box being connected to the switch. Ten motors are the maximum to be operated by one, 15 amp switch.

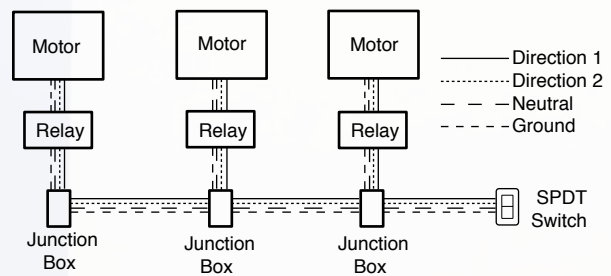

Wireless Remote Control (WRC) - Radio Frequency (RF)

A radio frequency system which is controlled by a hand-held transmitter. It is omnidirectional, digital coded, and has a maximum range of 100'. Transmitters are available to control from 1-24 motors, with individual, group and subgroup operation options.

Wireless Remote Control (WRC) - Infrared (IR)

The system is directional, digital coded and has a maximum range of 50 feet. Infrared systems are not subject to possible interference from outside sources, as is sometimes the case with radio frequency controls, but must have line of sight between the transmitter and sensor. Transmitters are available to control from 1-24 motors, with individual, group and subgroup operation options.

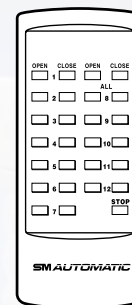

Electrical wiring required for either RF or IR wireless remote control, is a standard 110 VAC duplex electrical outlet.

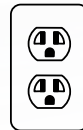

Control System Interface

When interfacing with a home theater, multi-room control system, or whole-house automation system; two (2) momentary dry contacts (switching contacts with no voltage inputted) are required.



Switch and Transmitter Options for Models 5100, 8000, 9600 and 9300 Series

Wall Switches

S-DEC2

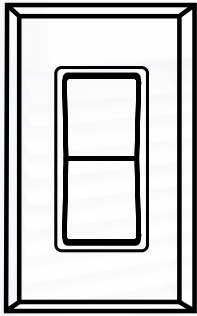

S-DEC1

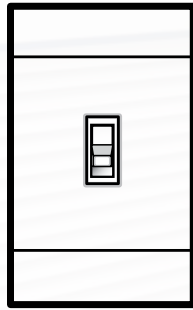

S-DEC5

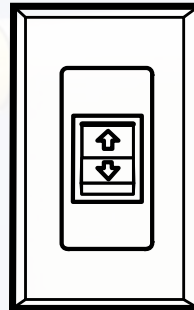

Radio Frequency and Infrared Remote Control

Custom transmitter configurations are available

RF/IR-T1

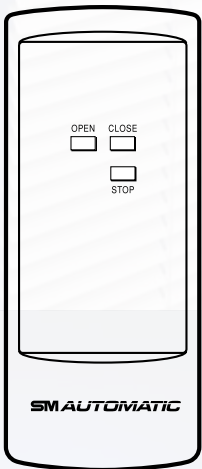

RF/IR-T2

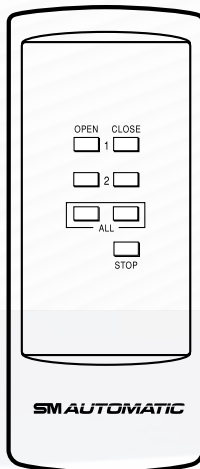

RF/IR-T4

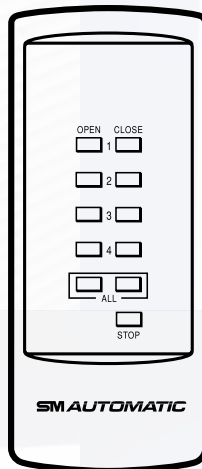

RF/IR-T12

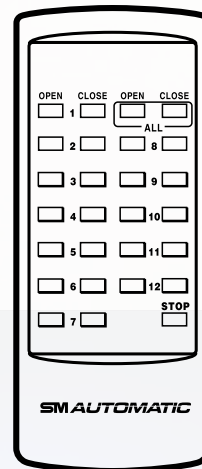

RF/IR-T24

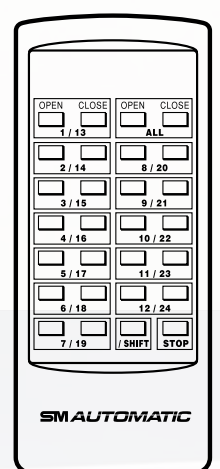

Radio Frequency and Infrared Remote Control Keypads

Custom keypad configurations are available

RF/IR-K1



RF/IR-K3

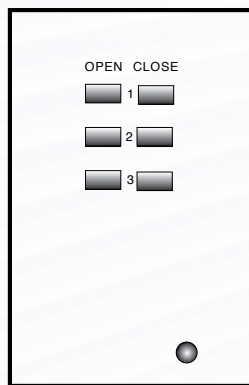

RF/IR-K4

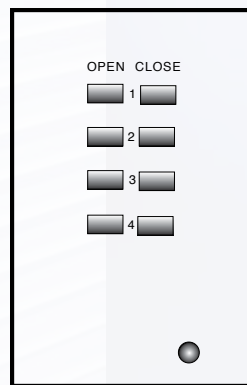

RF/IR-K6

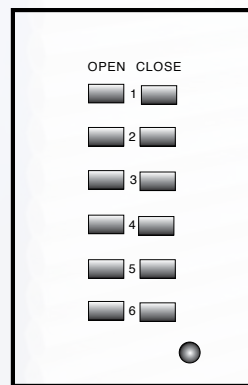

RF/IR-K12

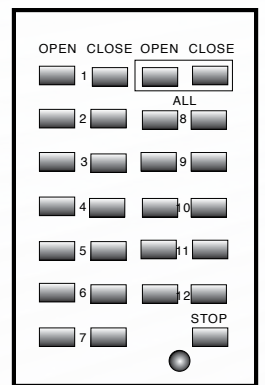

Electrical/Electronic Control and Wiring Information Legend

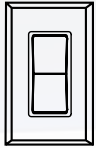

S-DEC2 Decora Paddle Switch



S-DEC1 Decorator Toggle Switch

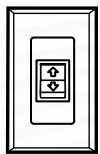

S-DEC5 Decora 5 Position Switch
(for Model 8000 only)

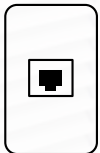

Modular Wall Jack (RJ-11)

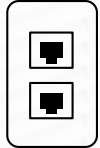

Modular Wall Jack Double (RJ-11)

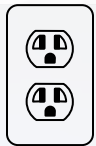

Standard 110 volt Duplex Outlet

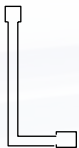

Modular Cable (four conductor: 4/26)

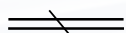

In-wall Modular Cable (four conductor: 4/26)
(supplied by others)

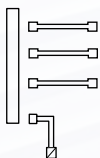

Splitter with Modular Cables and
Infrared Receiving Eye



Radio Frequency Receiver

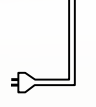

Infrared Receiver

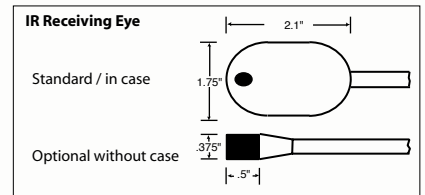

Control System Interface

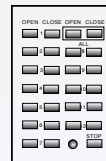

Infrared or Radio Frequency
Receiver Keypad

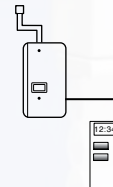

Timer



Automation Control System
(supplied by others)



Automation Control System
User Interface
(supplied by others)

Electrical Wiring Diagrams for Models 5100, 8000, 9600 and 9300 Series

A. Hard wired Individual SPDT Control

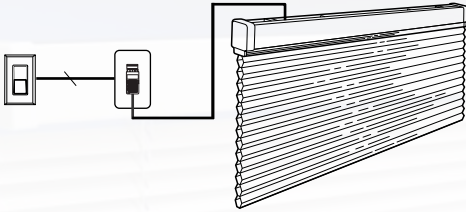

Optional Hard wiring Plug and Receptacle (PR)

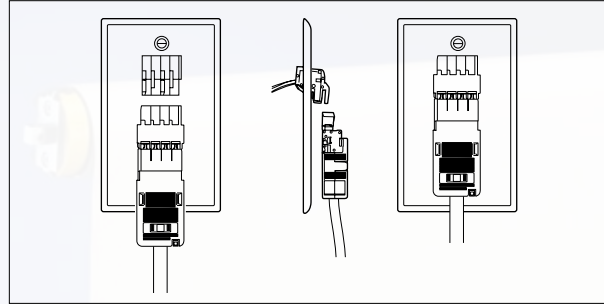

B. Hard wired Group Control using Isolation (parallel) relays

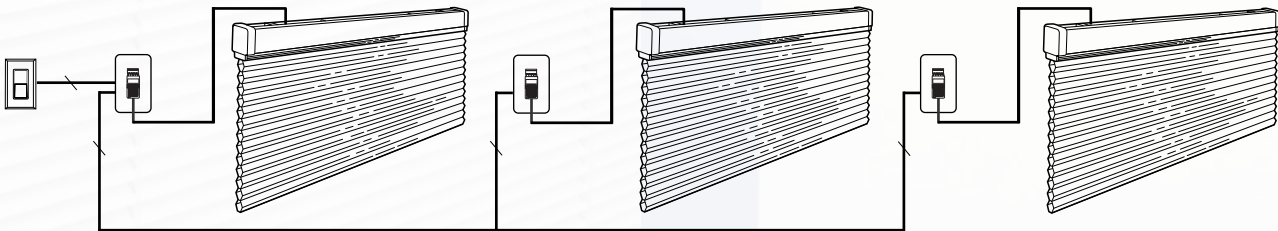

C. Individual Radio Frequency Remote Control

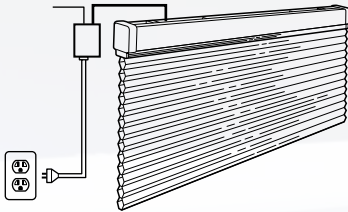

D. Individual Radio Frequency Remote Control with SPDT switch

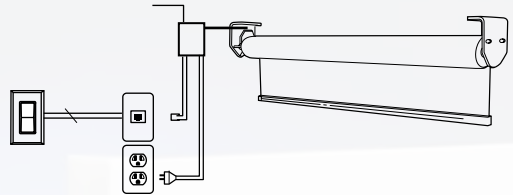

E. Individual Infrared Remote Control

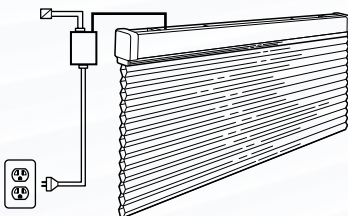

F. Individual Infrared Remote Control with SPDT switch

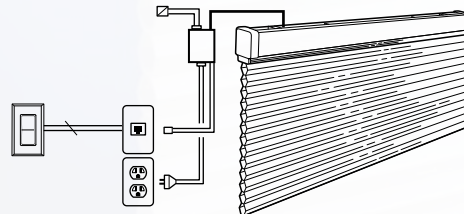

Remote control receivers, relays and low voltage interfaces, are located inside the head rails on models 9600 and 8000; and are external on models 5100, 9300 and 9700 series motors.

Electrical Wiring Diagrams for Models 5100, 8000, 9600 and 9300 Series

G. Automation Control System



H. Automation Control System with SPDT Switch

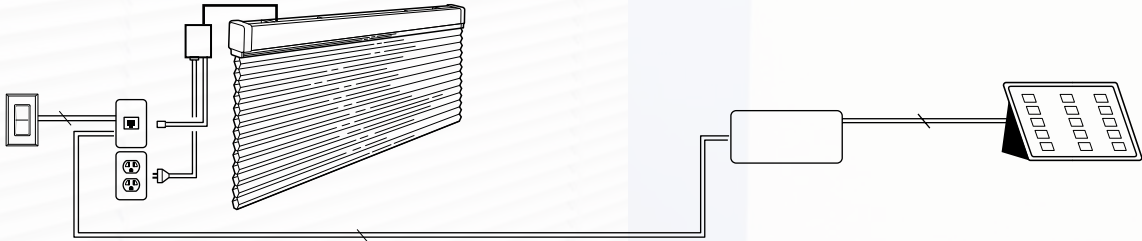

I. Automation Control System with Infrared (or Radio Frequency) Remote Control



J. Automation Control System with Infrared (or Radio Frequency) Remote Control and SPDT Switch

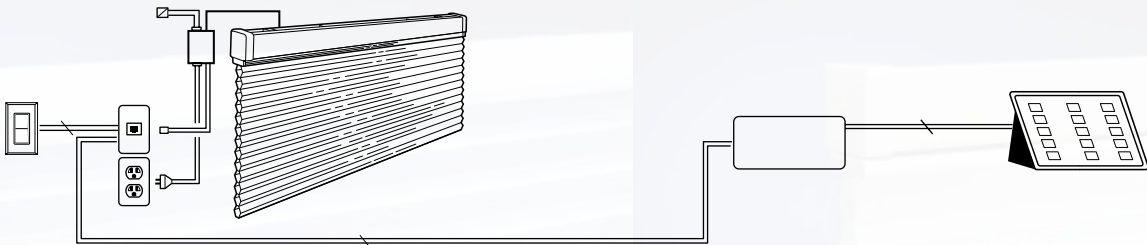

K. Modular Wiring for Automation Control System

Modular RJ-11 Plug Connection

- Yellow - Down Direction
- Green - Common (common to Yellow)
- Red - Up Direction
- Black - Common (common to Red)

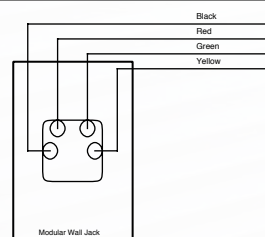
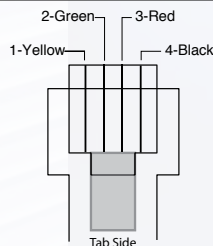

Remote control receivers, relays and low voltage interfaces, are located inside the head rails on models 9600 and 8000; and are external on models 5100, 9300 and 9700 series motors.

Electrical Wiring Diagrams for Models 5100, 8000, 9600 and 9300 Series

L. Individual and Group Infrared Control using multiple Keypads

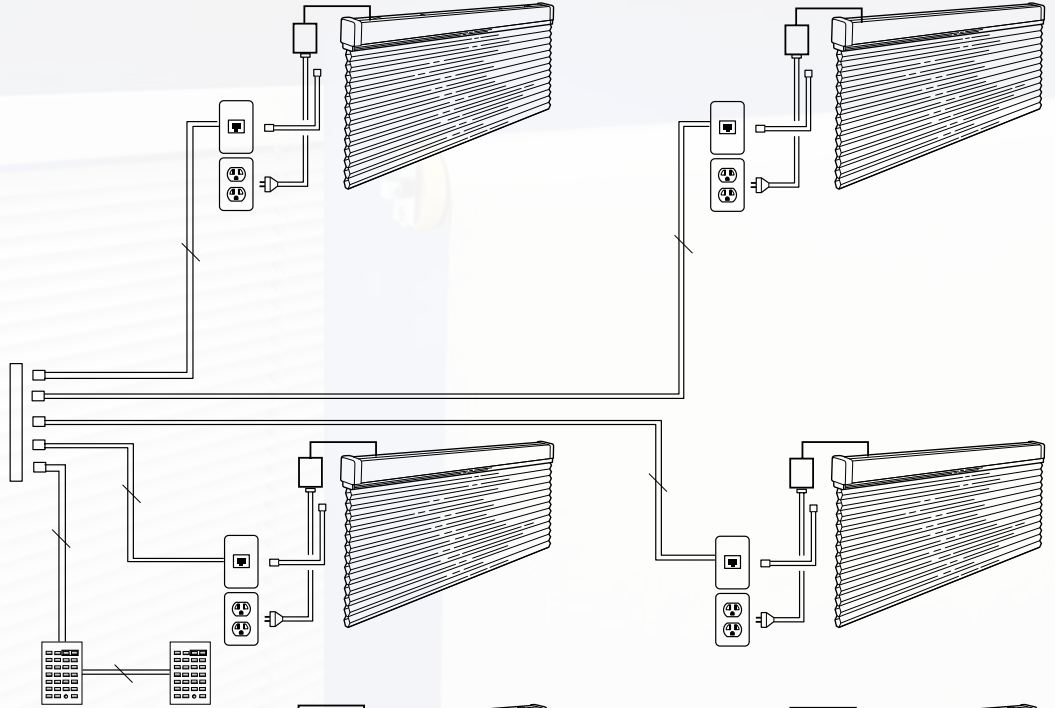

M. Individual and Group Infrared Control using Keypad(s) and Timer

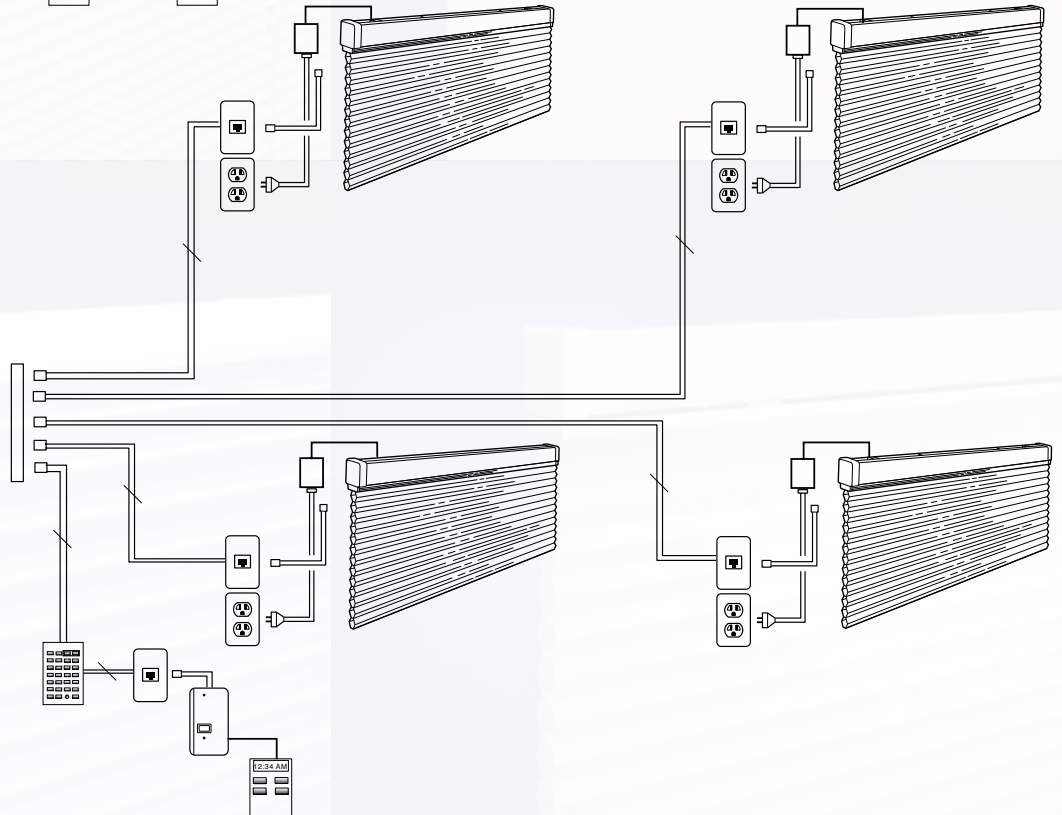

Remote control receivers, relays and low voltage interfaces, are located inside the head rails on models 9600 and 8000; and are external on models 5100, 9300 and 9700 series motors.

Electrical Wiring Diagrams for Models 5100, 8000, 9600 and 9300 Series

N Individual and Group Infrared Remote Control using Keypad without Modular Wall Jacks

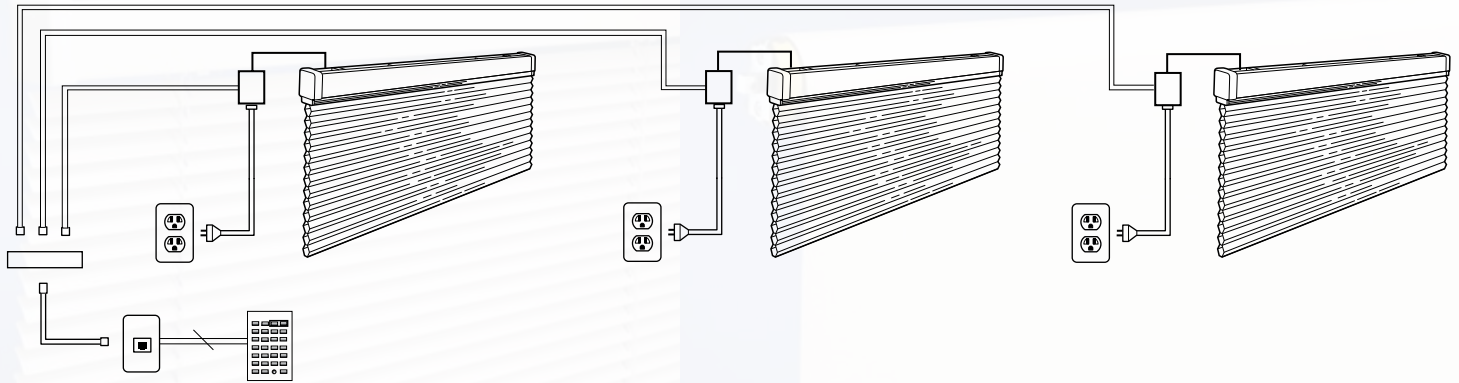

O Individual and Group Infrared Remote Control using Keypad with Modular Wall Jacks

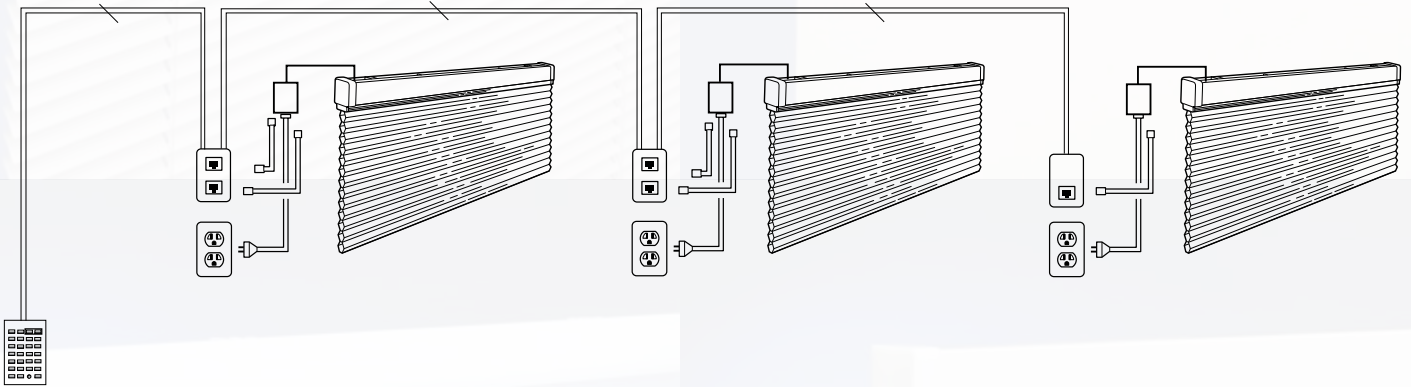

P Timer Control

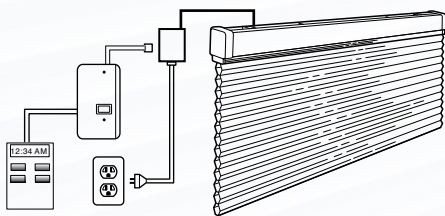

P Infrared Remote and Timer Control

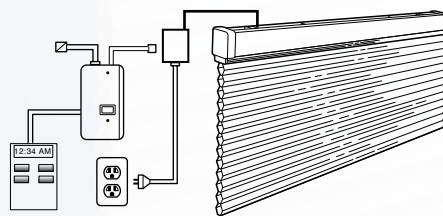

Remote control receivers, relays and low voltage interfaces, are located inside the head rails on models 9600 and 8000; and are external on models 5100, 9300 and 9700 series motors.

Electrical Wiring Diagrams for Models 5100, 8000, 9600 and 9300 Series

Q. Individual and Group Infrared Remote Control with Modular Wall Jacks

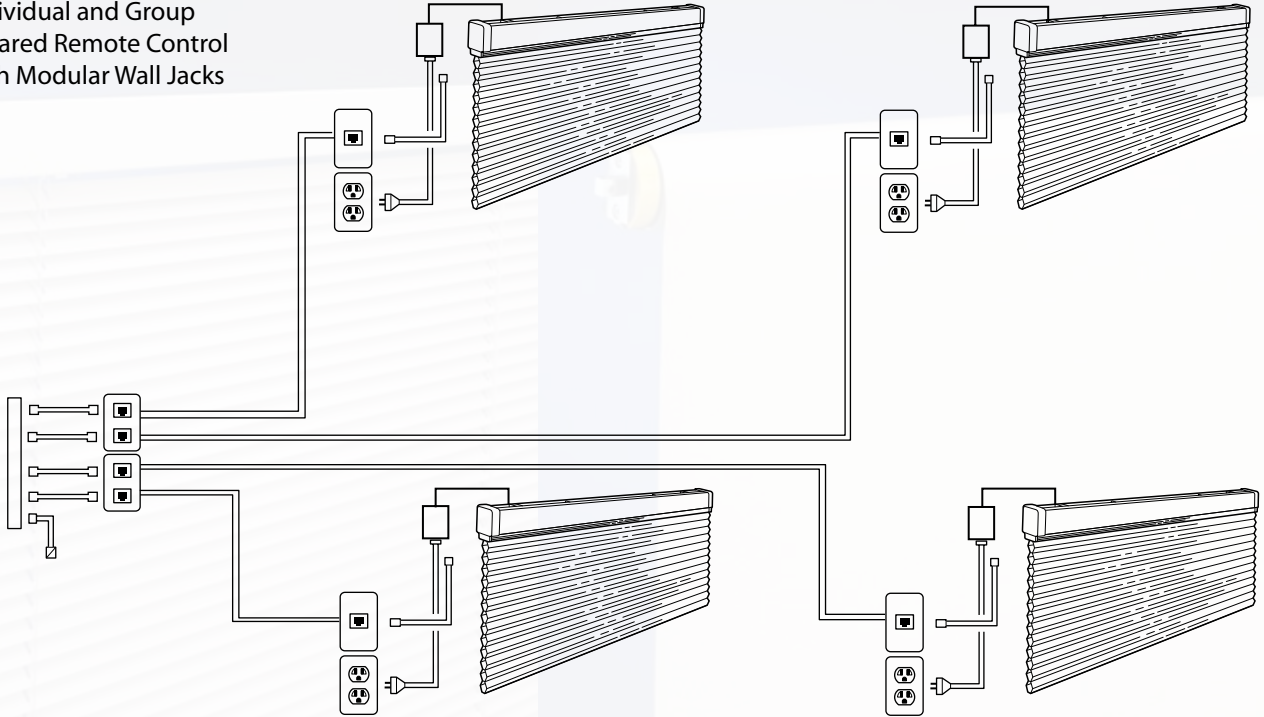

R. Individual and Group Infrared Remote Control without Modular Wall Jacks

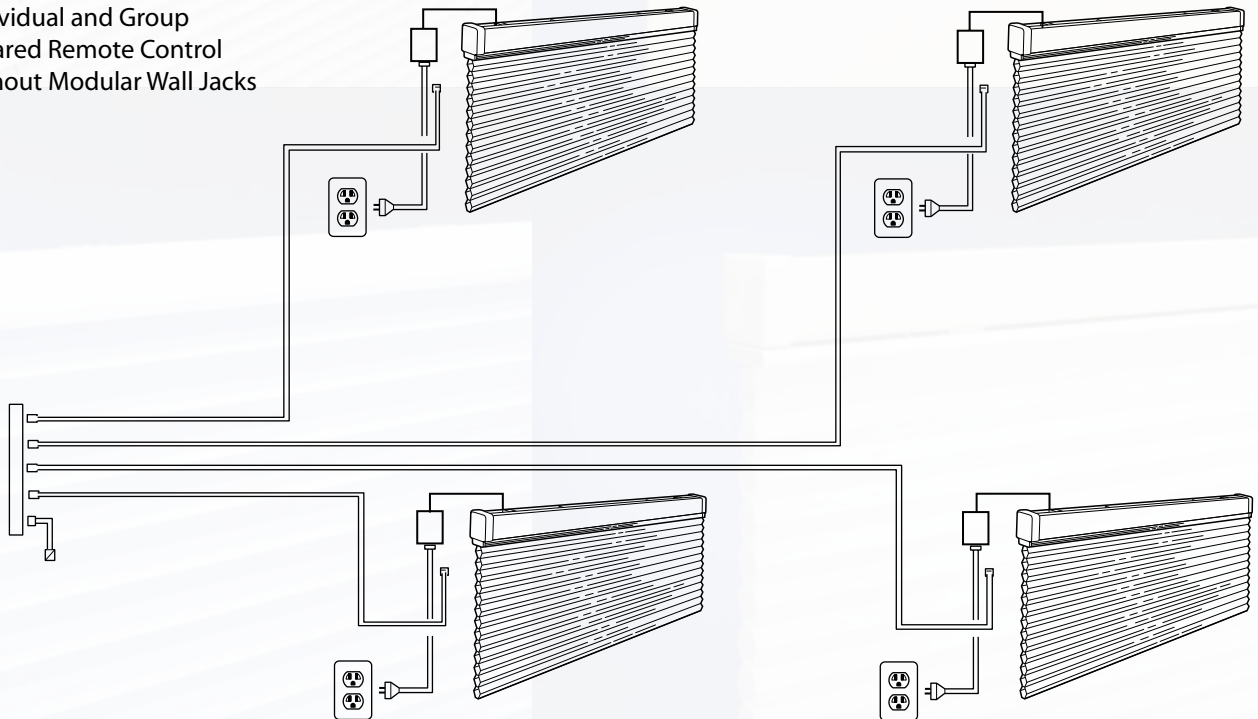

Remote control receivers, relays and low voltage interfaces, are located inside the head rails on models 9600 and 8000; and are external on models 5100, 9300 and 9700 series motors.

Electrical Wiring Diagrams for Models 5100, 8000, 9600 and 9300 Series

S. Individual and Group Infrared Remote Control with Keypad

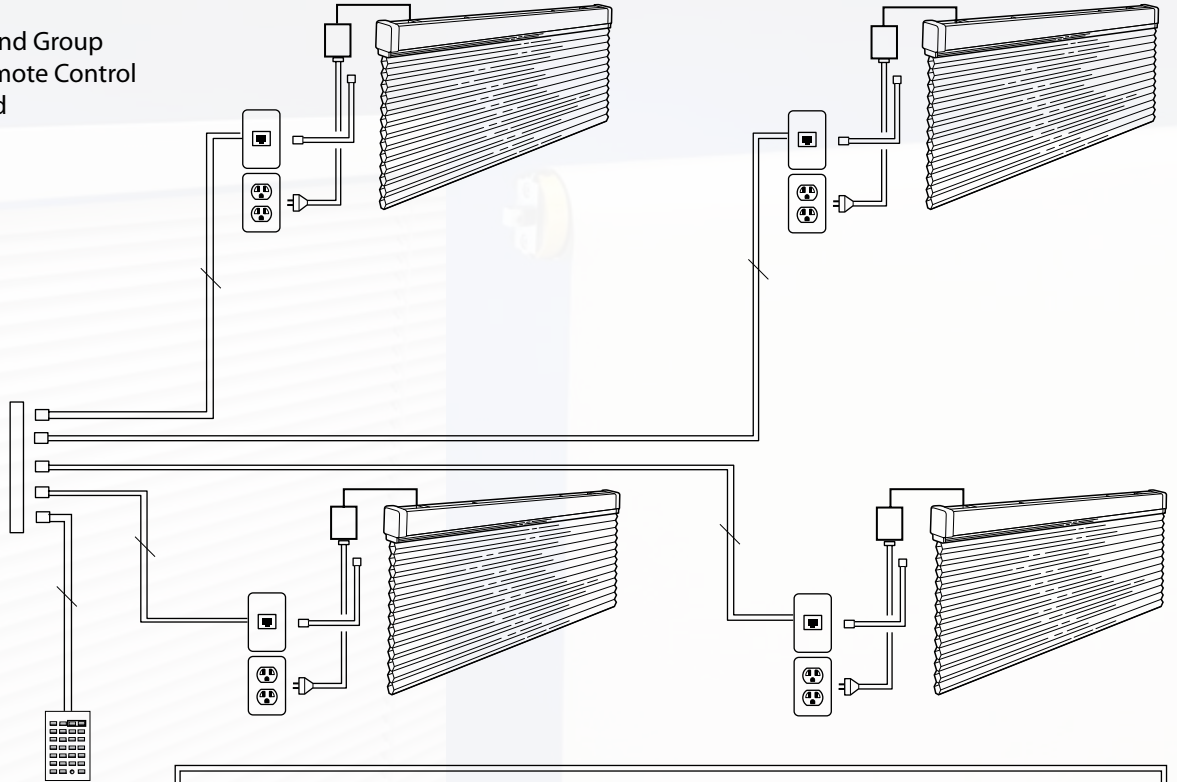

T. Individual and Group Infrared Remote Control with Keypad and Automation Control System

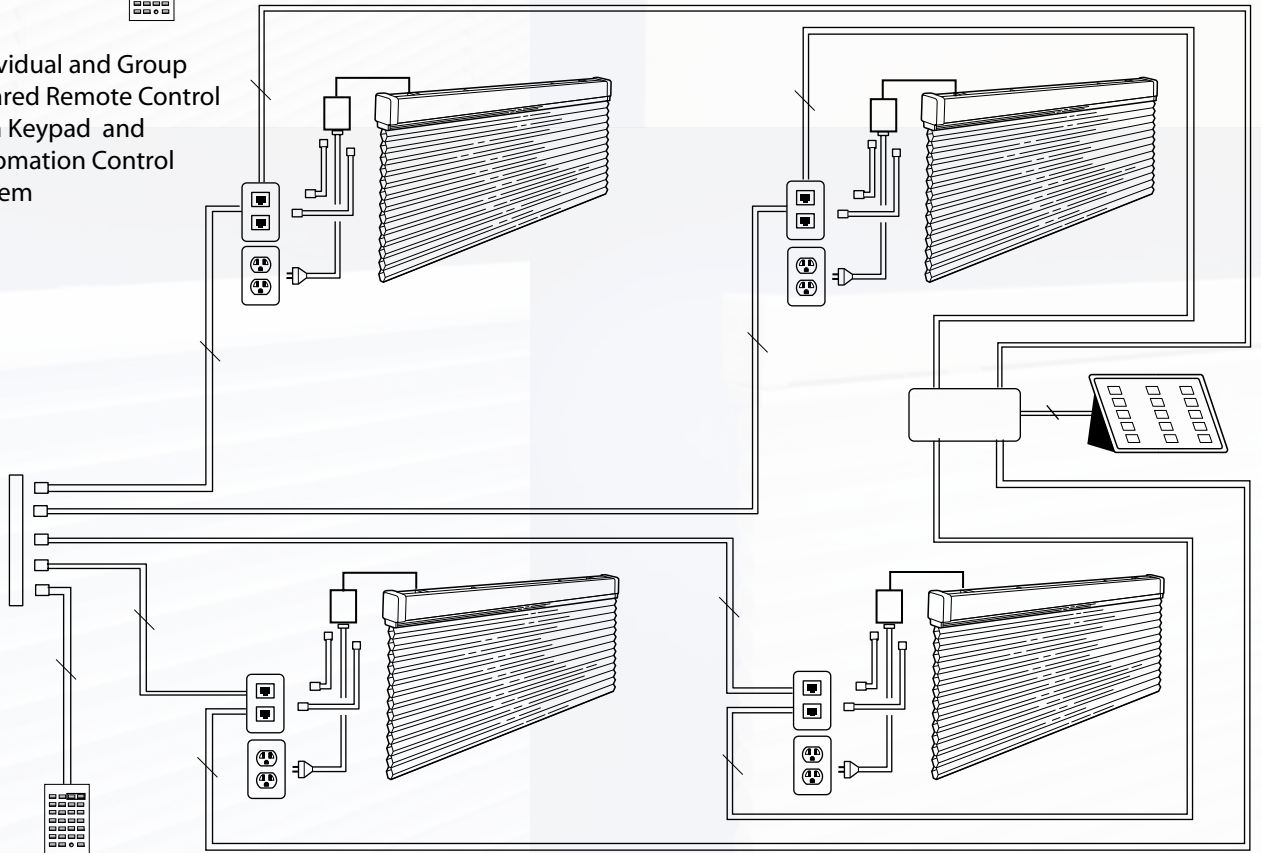

Electrical Wiring Diagrams for Models 5100, 8000, 9600 and 9300 Series

U. Individual and Group Infrared Remote Control with Keypad

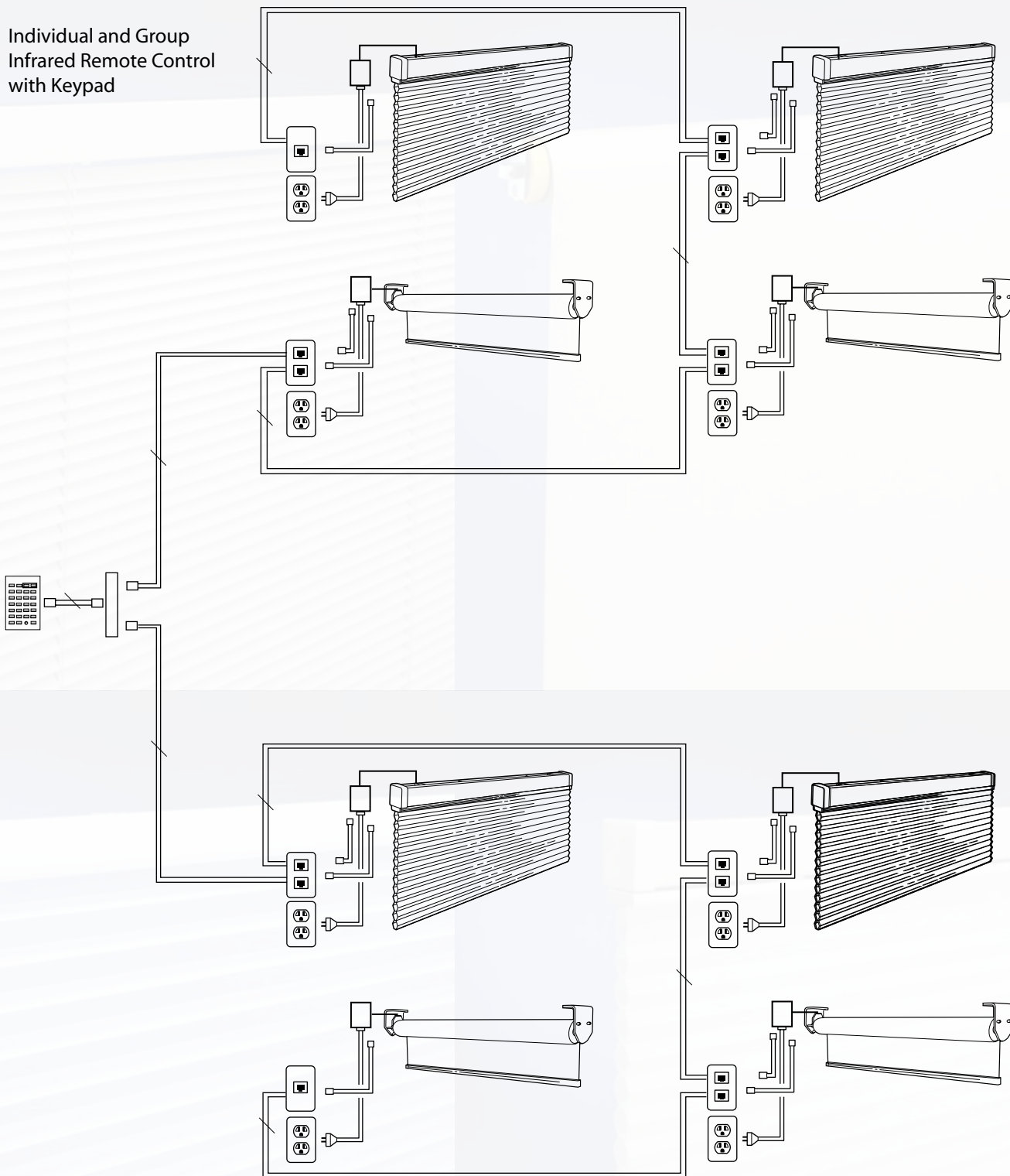

Remote control receivers, relays and low voltage interfaces, are located inside the head rails on models 9600 and 8000; and are external on models 5100, 9300 and 9700 series motors.

Electrical Wiring Diagrams for Models 5100, 8000, 9600 and 9300 Series

V. Control System Interfaces Installed within a Centralized Control Panel

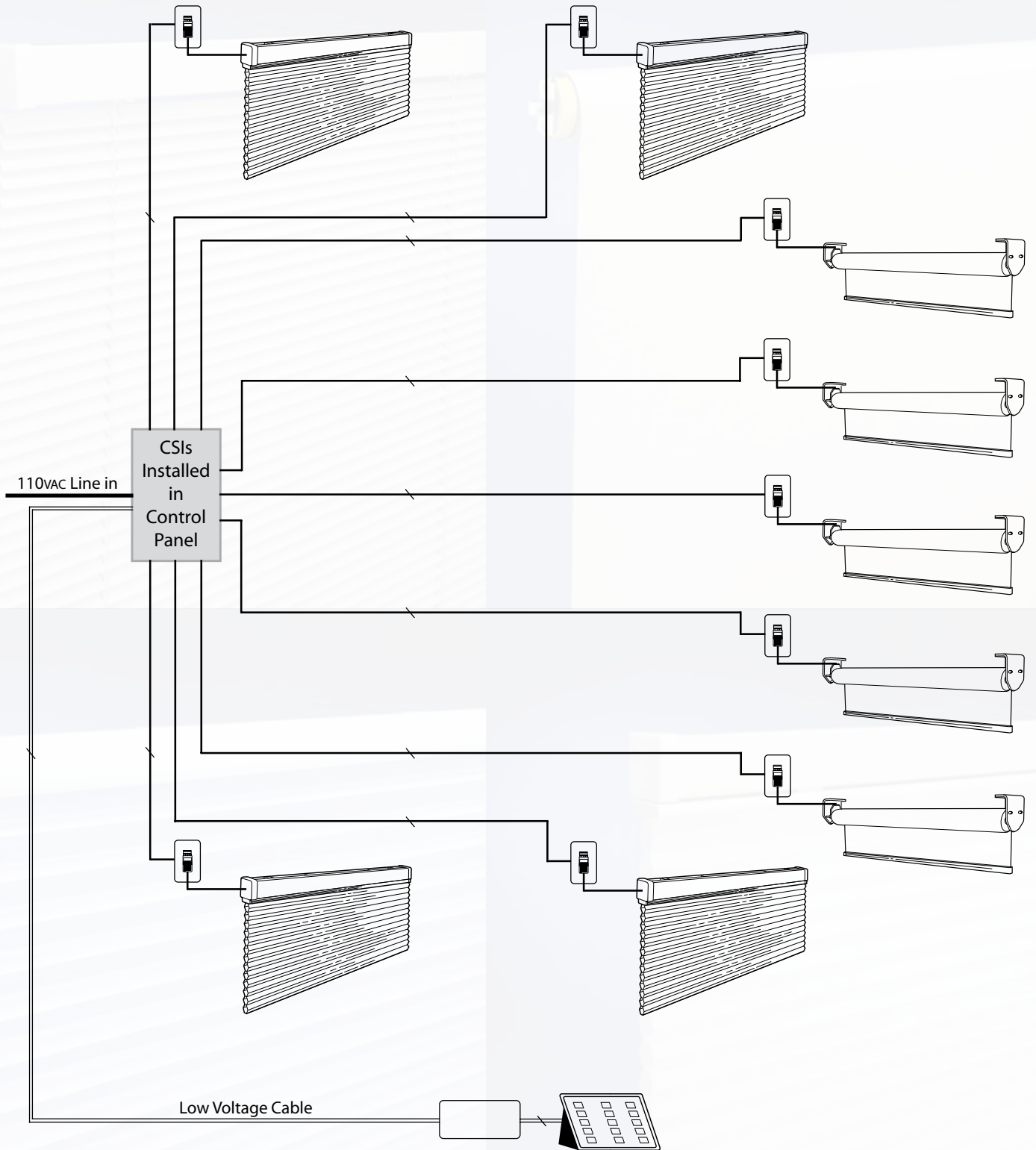

Electrical Wiring Diagrams for Models 5100, 8000, 9600 and 9300 Series

W. Individual and Group Infrared Remote Control with Automation Control System

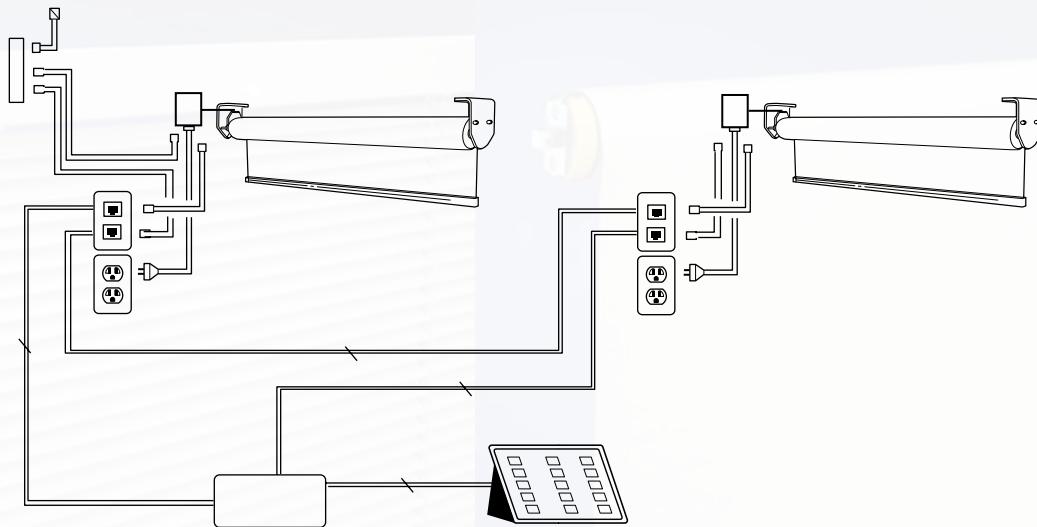

X. Model 9300 series motor and Drapery Motor, with Automation Control System and SPDT Switch

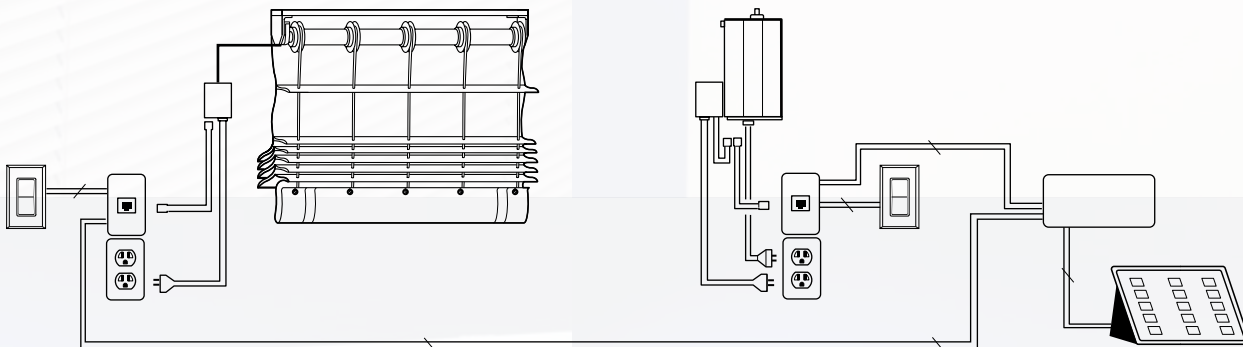

Important Information Regarding Radio Frequency Interference

All radio frequency (RF) wireless remote control systems are subject to radio wave interference. When present, RF interference may be constant or intermittent.

According to FCC regulation, equipment used for RF wireless remote controlled window treatments, must follow these guidelines:

“Operation is subject to the following two conditions: (1) This device may not cause harmful interference and (2) this device must accept any interference that may be received, including interference that may cause undesired operation.”

Electrical Wiring Information and Diagrams - A Comparative Guide for Automation Control Systems

Roman and roller shades

When interfacing with a home theater, multi-room control system, or whole-house automation system; two (2) momentary dry contacts are required.

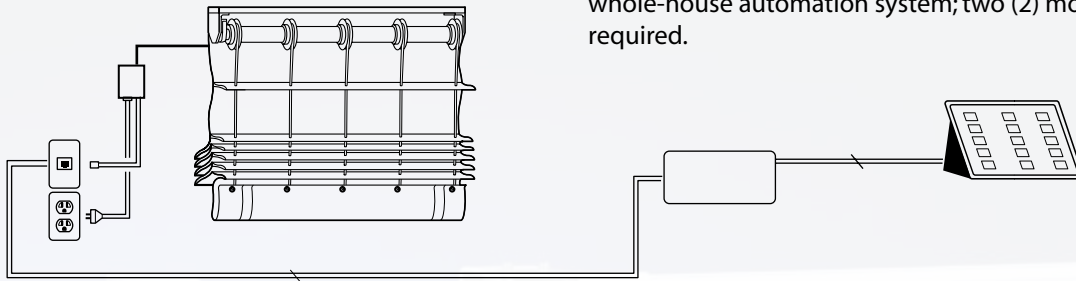

Cellular shades

When interfacing with a home theater, multi-room control system, or whole-house automation system; two (2) momentary dry contacts are required.

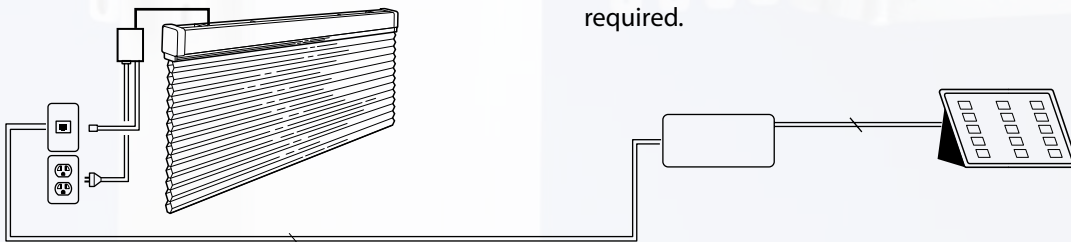

Horizontal blinds

When interfacing with a home theater, multi-room control system, or whole-house automation system; two (2) SETS of momentary dry contacts are required. One set of contacts for "tilting" function must have timed contacts of less than 1.5 seconds. The second set of contacts for "lifting" function must have a timed contact of more than 1.5 seconds.

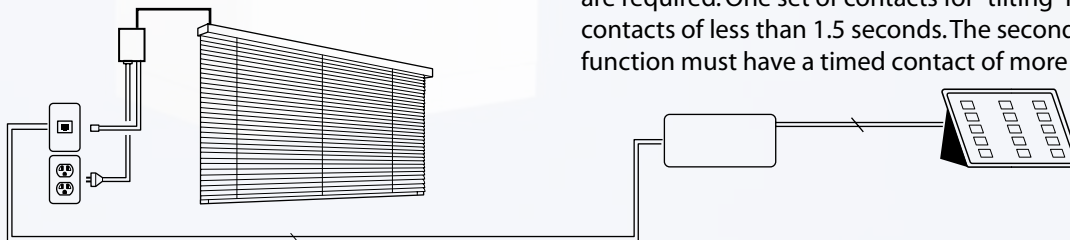

Modular Wiring for Shades and Blinds Connecting to an Automation Control System

Modular RJ-11 Plug Connection

- Yellow - Down Direction
- Green - Common (common to Yellow)
- Red - Up Direction
- Black - Common (common to Red)

