

Installation Information

SM AUTOMATIC General Installations Instructions

All SM Automatic motorized window treatment systems must be installed by experienced professional installers.

SM Automatic provides heavy duty mounting brackets.

Fasteners are not included.

Appropriate fasteners must be used by the installer, as required to securely mount each window treatment system to the ceiling, wall, or window frame.

Since construction materials vary, it is up to the installer to determine which type of fasteners are required.

Since motorized systems are generally heavier than manual systems, extra consideration must be taken when determining the type and quantity of fasteners needed.

Wood backing is recommended for proper and secure attachment of mounting brackets to drywall or plaster walls and ceilings.

SM Automatic supplies motorized systems exclusively to the window covering trade only, and assumes no responsibility for installation.

It is the responsibility of the installer to determine and provide proper fasteners to accommodate the weight and security of the product.

Installers should not hesitate to call SM Automatic with any questions or concerns regarding installation or adjustment of any of our products.

Installation Information Model 300 Series Direct Drive

Installation

SM Automatic Model 300 series direct drive drapery track systems, using our 30, 40, and 90 series tracks, are installed using ceiling or wall mounting brackets, or by screwing directly thru the track. When screwing directly thru the track, flat head screws must be used, in order to avoid obstructing the movement of the track components.

Brackets should be installed at approximately 8" from the ends, and intermittently, at least 36" on center. For ceiling mounting, a screw should be installed thru the end flange of the motor drive pulley also.

It is highly recommended that you attach the brackets onto the track system before installation, to familiarize yourself with the operation of the brackets.

The maximum size for a single unspliced track is 20'. Tracks over 20' must be spliced. Other considerations for splicing are due to shipping, access, and handling issues. If a track is spliced, re-assemble it before installation, taking great care to assure that the cable does not become twisted inside the track. It is also crucial to properly install splice brackets on the 90 track. The splice must be installed perfectly so it joins the tracks together, assuring that there is no gap between the tracks.

Fasteners are not included.

Please refer to general installation instructions on page 66.

Attaching the Motor:

Model 300 series drapery motors are attached to the direct drive track system drive pulleys as follows, after the track has been installed:

1. Align motor shaft with shaft hole in drive pulley wheel, and simultaneously align motor lock-pins with keyhole slots in drive pulley housing.
2. Insert shaft into drive pulley wheel, insert lock-pins into keyhole slots, twist-lock motor into alignment with pulley housing.
3. Slide locking plate all the way up so it is in place to secure motor to drive pulley, and tighten thumb screw. Test that the motor is secure before releasing or operating.

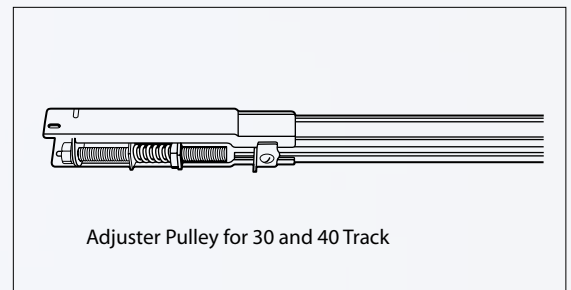
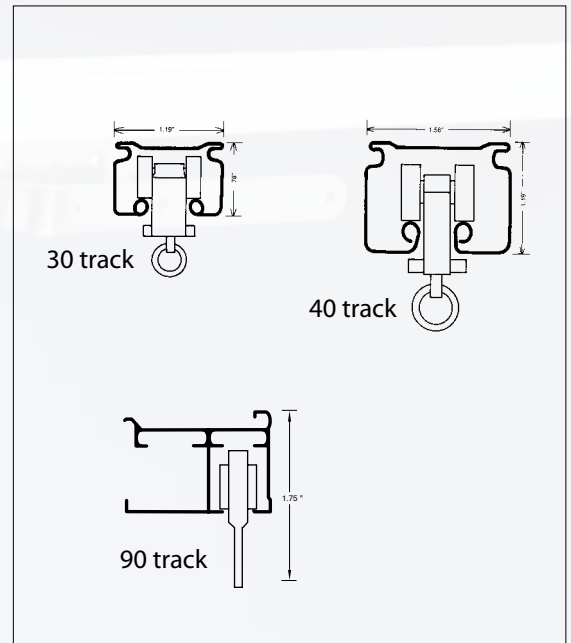
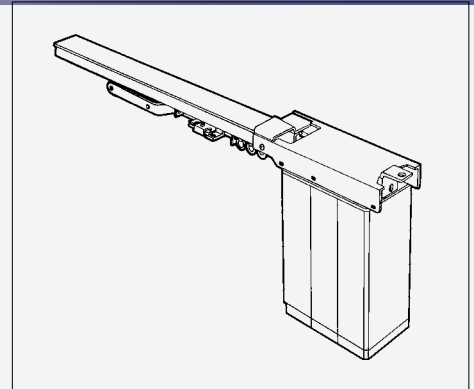

Installation Information Model 300 Series Direct Drive

Installation

Minor adjustment of the cable tensioning might be required. This is achieved by tightening or loosening the tensioning adjuster bolt. On the 90 series tracks, this adjuster is located on the master carrier. On the 30 and 40 series tracks, this adjuster is located in the end pulley housing.

If the motor stops prematurely, the tension is too tight. To loosen the tension, turn the tensioning adjuster bolt counter clockwise, a little bit at a time, until the motor operates properly.

If the motor keeps running after reaching the fully open or closed position, the tension is too loose. To tighten the tension, turn the tensioning adjuster bolt clockwise, a little bit at a time, until the motor operates properly.

There are no adjustments required to the motor itself. The limits are electronic and any adjustment necessary is done at the factory and should not be attempted by anyone other than a factory technician.

Motors are controlled as follows: SM Automatic switch, SM Automatic remote control systems, or other authorized home automation systems, using momentary dry contacts. Wiring required from controllers is 26 AWG / 4 conductor (26/4) low voltage modular cable, and is attached to the motor control port with RJ-11 type plug. All controllers and control accessories are supplied separately.

Electrical

Electrical wiring and attachment must conform to local building and electrical codes.

A live (non-switched) 110VAC duplex outlet receptacle is required for power. Location of the outlet should be determined according to the conditions of the window & wall. The outlet may be installed in either the ceiling, wall, header, jamb, or any area determined by the electrician.

The ideal location of the outlet is as close to the end of the drapery track system as possible. It should be installed to be clear of the track and motor and in a location so it does not interfere with the operation of the drapery track system. 12" below the end of the track is recommended.

